

Acoustic Enclosure 600 – as a modular Accessory to Micro 40 Systems

Halcyonics manufactures acoustic enclosures to protect sensitive equipment setups from airborne noise; the Acoustic Enclosure 600 is supplied as an accessory for the Micro 40 active isolation systems.

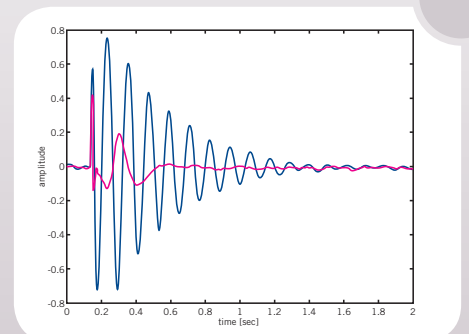

Acoustic Enclosure 600

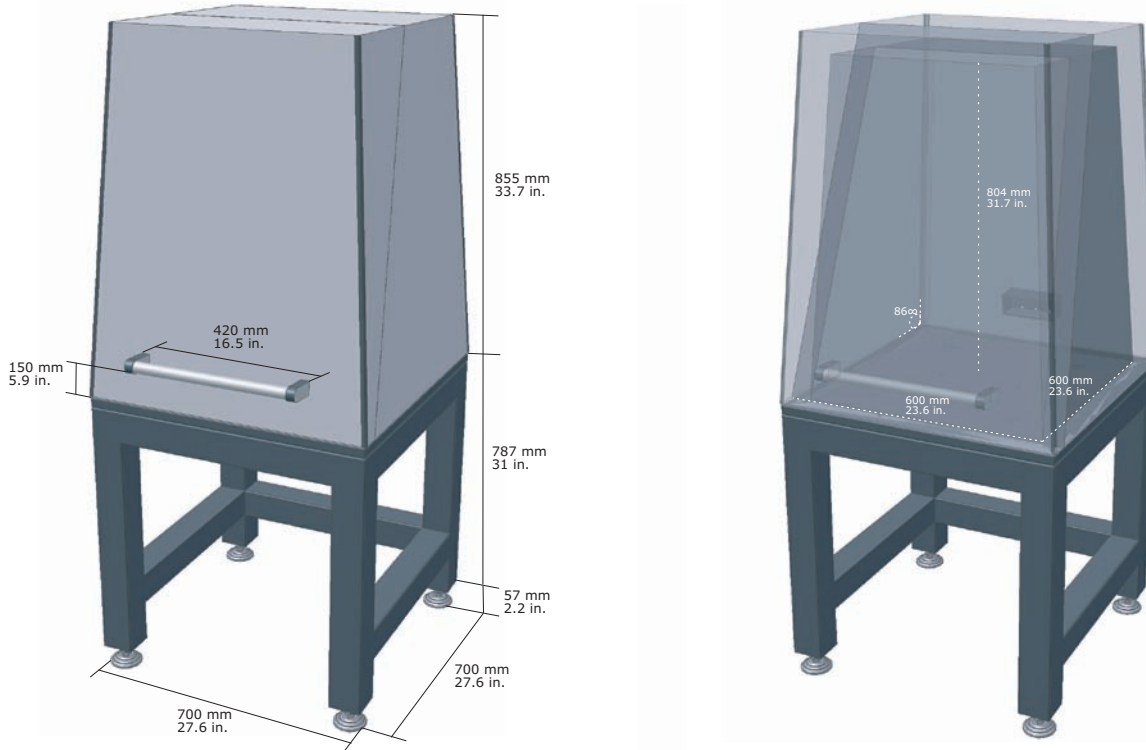

▲ Fig. 1: Dimensions of Acoustic Enclosure 600 mounted to optional steel frame, which needs to be ordered separately!

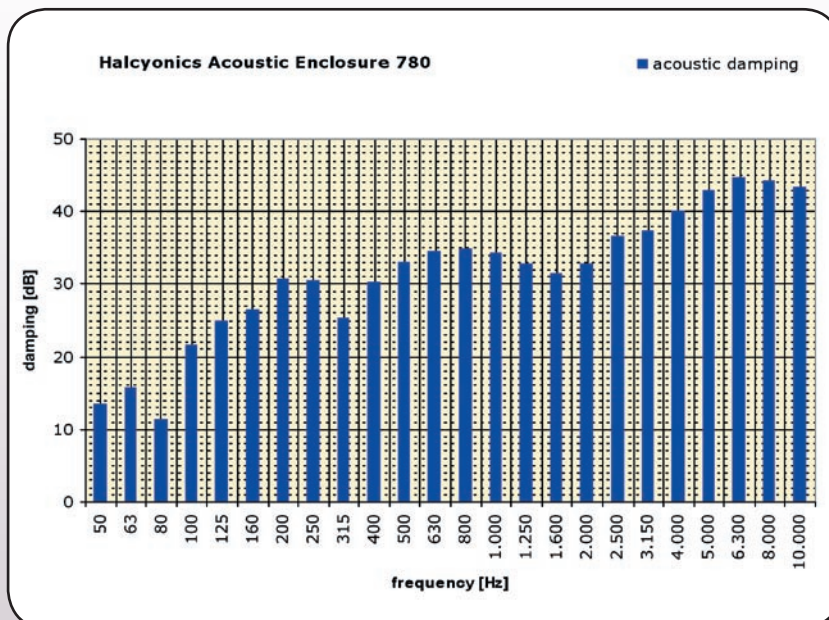

▲ Fig. 2: The above measurement has been performed with an Acoustic Enclosure 780. The damping performance of the Acoustic Enclosure 600 is comparable or even better.

Features and benefits

- Modular design, available with optional rigid steel frame
- Front door lifted by the gas pressure actuated mechanism
- Multi-layer wall construction for optimal broadband damping
- Walls are inclined at 4 degrees, thereby effectively preventing sound waves from spreading